

Note!

Please note that there can be small differences between your product and the images in these instructions.

Note!

Please note that during storage and transport, especially at high ambient temperature, some of the oil and grease used for assembly may leak and stain the packaging. This will not cause damage to the product, wipe off the excessive oil or grease with a cloth.

Kit contents

| Description | Part No | Pcs |
|----------------------|----------|-----|
| Shock absorber | TR 361 | 1 |
| Sticker Memo notes | 01180-01 | 1 |
| Sticker Öhlins wh/tr | 01185-01 | 2 |
| Sticker Öhlins bl/tr | 01185-04 | 2 |
| Owner's Manual | 07242-05 | 1 |

Note!

Before you install this product, check the kit contents. If anything is missing, please contact an Öhlins dealer.

Warning!

Before you install this product, read the Öhlins Owner's manual. This product is an important part of the vehicle and the vehicle stability.

Shock absorber for Triumph Daytona 675R

TR 361

Mounting Instructions



MOUNTING INSTRUCTIONS

Warning!

We strongly recommend to let an Öhlins dealer install this product.

Warning!

If you work with a lifted vehicle, make sure that it is safely supported to prevent it from tipping over.

Note!

When you work with this product, see the vehicle service manual for vehicle specific procedures and important data.

Note!

Before you install this product clean the vehicle.

1

Put the motorcycle on a work stand so that the rear wheel barely touches the ground.

2

Remove the lower and the upper attachment bolts of the original shock absorber.

3

Remove the original shock absorber from the left side of the vehicle.

4

Use the original bolts. First attach the upper bolt then attach the lower bolt to install the Öhlins shock absorber.

5

Install all removed parts in the same positions as they were before removal.

Note!

Lower the vehicle so that the suspension is slightly compressed before you tighten the screws.

Caution!

Make sure that you tighten all screws to the correct torque and that nothing fouls or restricts movement of the shock absorber/front fork/steering damper when the suspension is fully compressed or extended.

MOUNTING INSTRUCTIONS

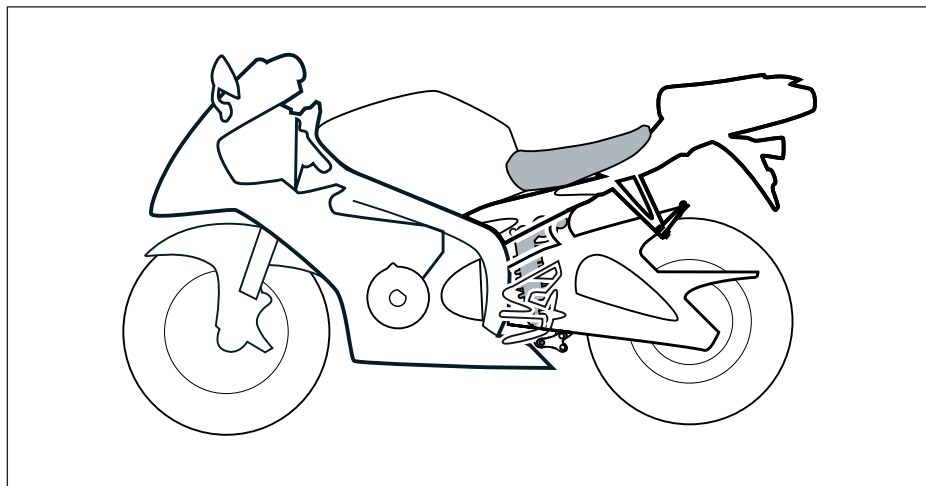

ADJUSTMENTS

⚠ Warning!

Before you ride/drive, always make sure that the setup is according to the recommended setup data. Read about adjustments and setting up in the Öhlins Owner's Manual before you make any adjustments. Contact an Öhlins dealer if you have any questions about setting up.

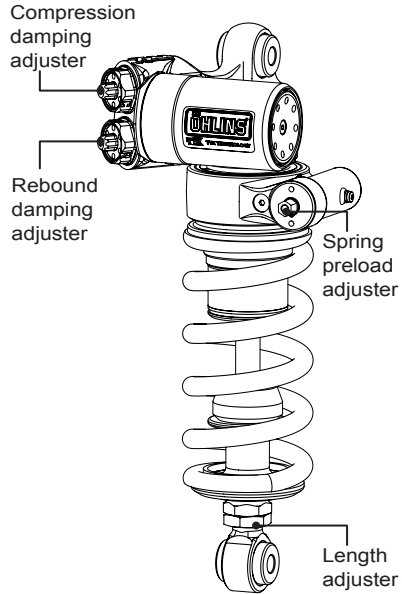

SETUP DATA

| | | |
|--------------------|-----------------|--------|
| Length | 295.5 +5.5/-0.5 | mm |
| Stroke | 60 | mm |
| Rebound | 18 | clicks |
| Compression | 14 | clicks |
| Spring part no | 21040-34 | |
| Spring free length | 160 | mm |
| Spring rate | 100 | N/mm |
| Spring preload | 14 | mm |

| Recommended Free sag and Ride height | | |
|--------------------------------------|----|----|
| R1-R3 | 30 | mm |
| F1-F3 | 37 | mm |

Öhlins products are subject to continuous improvement and development, therefore, although these instructions include the most up-to-date information available at the time of printing, minor updates may occur.

To find the latest information contact an Öhlins distributor. Please contact Öhlins if you have any questions regarding the contents in this document.

Part no. MI_TR361_0
Issued 2014-11-18

© Öhlins Racing AB. All rights reserved. Any reprinting or unauthorized use without the written permission of Öhlins Racing AB is prohibited.

Öhlins Racing AB
Box 722
S-194 27 Upplands Väsby, Sweden
Phone +46 8 590 025 00
fax +46 8 590 025 80



www.ohlins.com