

Kit Contents

Description	Part No	Pcs
Top Cap	60005-30	2
O-ring 20.3x2.4	00438-54	2
Spring 24.2/235/5.5	68016-55	2
Spring 24.2/235/6.5	68016-65	2
Preload tube	60062-05	2
Washer 24x12-3	60052-02	10
Sticker "ÖHLINS"	01185-04	2
Sticker "ÖHLINS"	01185-01	2
Sticker "ÖHLINS"	00192-01	2

Note!

Before installing this product, check the contents of the kit. If anything is missing, please contact an Öhlins dealer.

Warning!

Öhlins cannot be held responsible for any personal injury or damage that may occur after installing the Öhlins spring kit. We strongly recommend to let an Öhlins authorized service center install this kit.

Warning!

After you have installed this product, taken a test ride at low speed to make sure that your vehicle has maintained stability.

Note!

Please note that this image is a general representation of the product and may differ slightly from your product.

Note!

Please note that during storage and transportation, especially at high ambient temperature, some of the oil and grease used for assembling may leak and stain the packaging. This is in no way detrimental to the product, wipe off the excessive oil/grease with a cloth.

Fork Spring Kit for Honda PCX 150/ PCX 150 Hybrid

FSK 136

Mounting Instructions



MOUNTING INSTRUCTIONS

Original Front Fork assembly

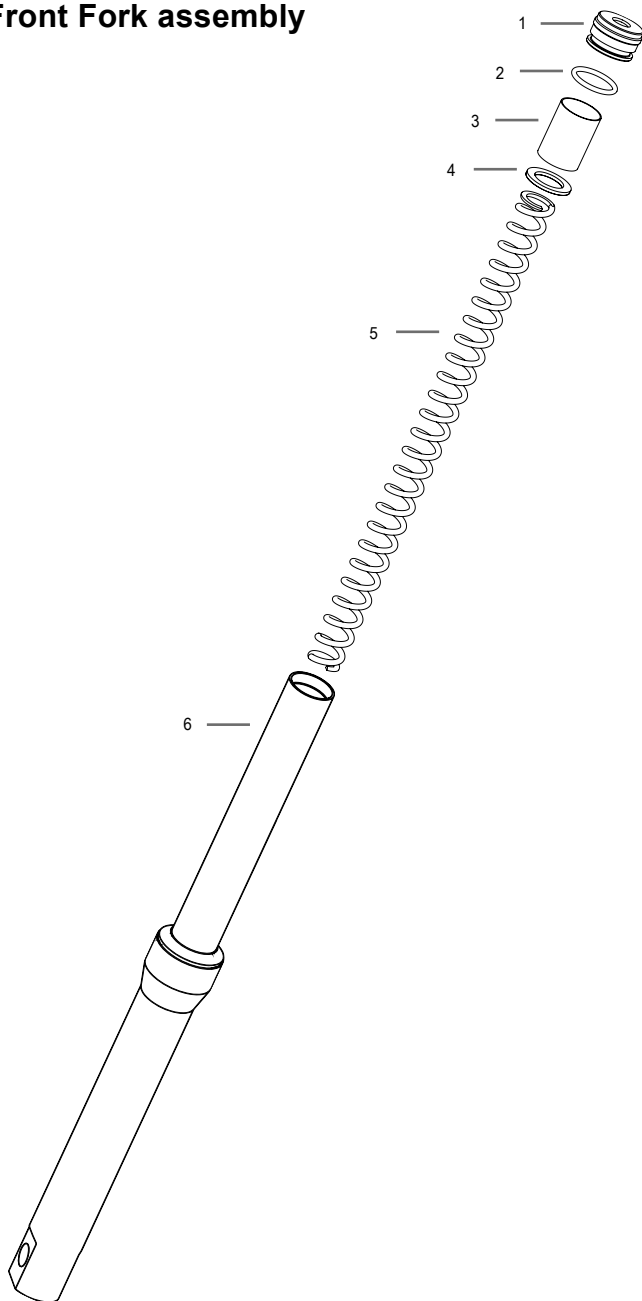

MOUNTING INSTRUCTIONS

Öhlins Front Fork kit assembly

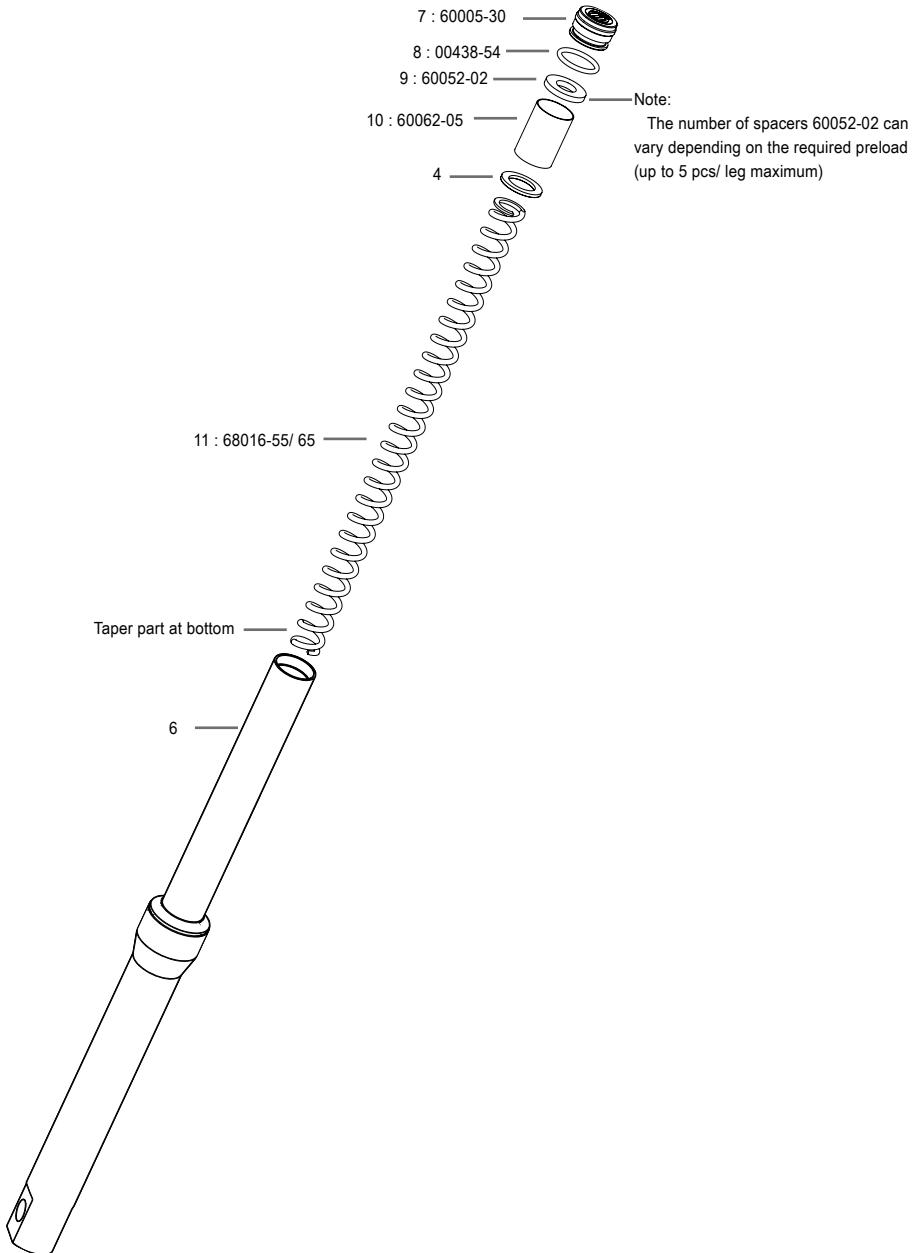

MOUNTING INSTRUCTIONS

Congratulations!

With this purchase you have made a clear statement. This high performance Front Fork kit from Öhlins is nothing but pure racing breed which means that you have taken one more step to eliinate luck on your motorcycle.

The balance between your Front Fork and rear suspension will sharpen up and the performance of your Front Fork will improve. Almost 40 years of racing experience is now a crucial part of your riding experience.

Recommended oil

For best performance we recommend to use a mix of Öhlins front fork fluid 01314 and 01316 at 1:1 mixing ratio (in a beaker unite 50% of 01314 and 50% of 01316). The final oil viscosity affects how the front fork will behave:

- Higher viscosity mix improves the feeling of control.
- Lower viscosity mix improves the comfort and traction. The oil mixing ratio can be tuned in order to match the rider preferences.

Recommended oil Level

68 mm.

Oil number	01314-01	01316-01
Viscosity cSt @40°C	40,0	98,0
Oil mixing ratio	1	1

👁️Note!

The measurement of oil level is taken from the top of the inner tube to the oil surface.

> The fork leg need to be in vertical position

> The fork need to be fully compressed

> The fork must be without the spring and the preload tube

👁️ Öhlins products are subject to continuous improvement and development, therefore, although these instructions include the most up-to-date information available at the time of printing, minor updates may occur.

How to install

- 1.Put the motorcycle on the work stand so that the front wheel barely touches the ground. Make sure the motorcycle is in a stable position.
- 2.Loosen the triple clamp screws and remove the front fork legs.
- 3.Press the top cap to remove the standard circlip.

👁️Note!

The standard circlip will be used in the next operations.

- 4.Purge all the oil from both fork legs.
5. Fill the Öhlins oil and install the Öhlins spring in both Fork Legs.
- 6.Insert the preload tube and washer (60052-02) 2 pcs/leg [Max 5 pcs/leg] for standard preload.
- 7.Install the Öhlins top cap using the standard circlip.

👁️Note!

Use a soft tool for push the top cap for don't damage the black color.

- 8.Re-install both fork legs as per vehicle service manual instructions.

👁️Note!

Öhlins FSK 136 spring 68016-55 rate is 5.5N/mm

Öhlins FSK 136 spring 68016-65 rate is 6.5N/mm

	Recommended spring		
Feeling	Soft	Medium	Hard
RH Leg	68016-55	68016-55	68016-65
LH Leg	68016-55	68016-65	68016-65

To find the latest information contact an Öhlins distributor. Please contact Öhlins if you have any questions regarding the contents in this document.

Part no. MI_FSK136_EN_0
Issued 2018-03-29

© Öhlins Asia Co. Ltd. All rights reserved. Any reprinting or unauthorized use without the written permission of Öhlins Racing AB is prohibited.

Öhlins Asia Co. Ltd
700/937 Moo5, Tambol Nongkhaga,
Amphur Phantong, Chonburi Province
20160 Thailand



www.ohlins.com