

Note!

Please note that there can be small differences between your product and the images in these instructions.

Note!

Please note that during storage and transport, especially at high ambient temperature, some of the oil and grease used for assembly may leak and stain the packaging. This will not cause damage to the product, wipe off the excessive oil or grease with a cloth.

Note!

Before installing this product, check the contents of the kit. If anything is missing, please check an Öhlins dealer.

Kit Contents

Description	Part No	Pcs
Shock absorber	DU 907	2
O-ring 14x4	00338-06	4
Spacer 12x22	02118-06	2
Spacer 12x24	02118-07	2
Sticker set"ÖHLINS"	10207-01	1
C-spanner S36	60710-01	2
Owners manual	07241-02	1

Warning!

Before installing this product, read the Öhlins Owner's Manual. The shock absorber is an important part of your vehicle and will affect the stability.

Shock absorber for Ducati Sport Classic 1000

DU 907

Mounting Instructions

MOUNTING INSTRUCTIONS

Warning!

We strongly recommend to let an Öhlins dealer install this product.

Warning!

If you work with a lifted vehicle, make sure that it is safely supported to prevent it from tipping over.

Note!

When you work with this product, see the vehicle service manual for vehicle specific procedures and important data.

Note!

Before you install this product clean the vehicle.

1

Put the motorcycle on a work stand so that the rear wheel barely touches the ground.

2

Loosen and remove the original shock absorber.

3

Install the Öhlins shock absorber in the same position as the original shock absorbers.

Note!

Lower the vehicle so that the suspension is slightly compressed before you tighten the screws.

Caution!

Make sure that you tighten all screws to the correct torque and that nothing fouls or restricts movement of the shock absorber/front fork/steering damper when the suspension is fully compressed or extended.

MOUNTING INSTRUCTIONS

1

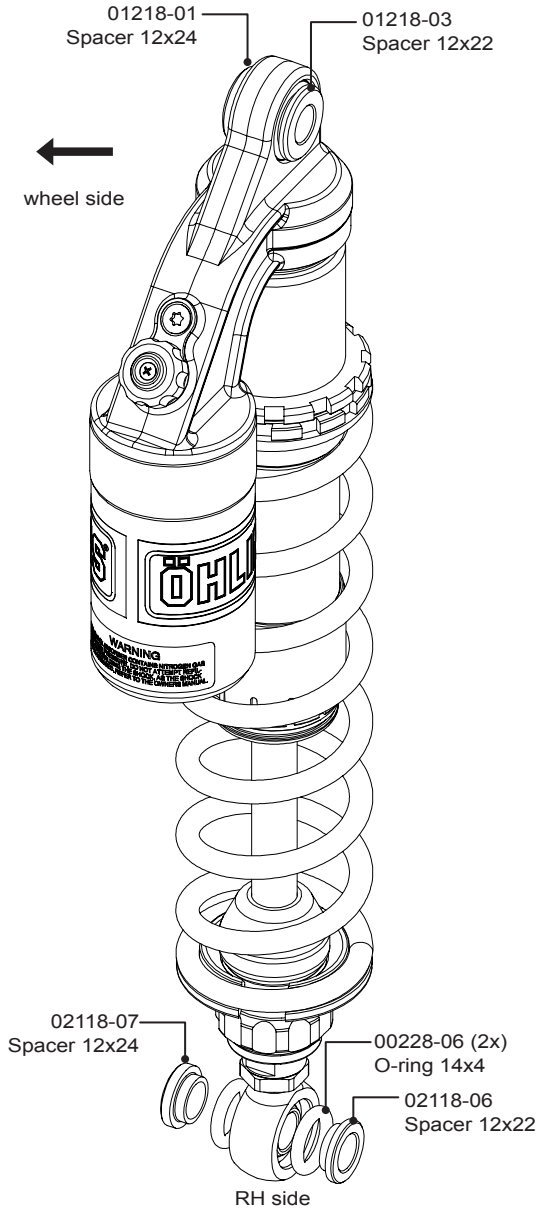

Note!

Mirrored position of spacers for the LH side

ADJUSTMENTS

⚠ Warning!

Before riding, always make sure that the basic settings made by Öhlins are according to recommended

Set-up Data. Read about adjustments and setting up in the Öhlins Owner's Manual before you make any adjustments. Contact an Öhlins dealer if you have any questions about setting up.

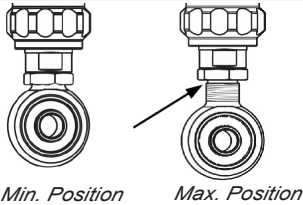

⚠ Warning!

The adjustable end eye/bracket must not be threaded out more than that the groove is fully visible beneath the lock nut. This is maximum length. After adjusting, make sure that the lock nut is tightened (30Nm).

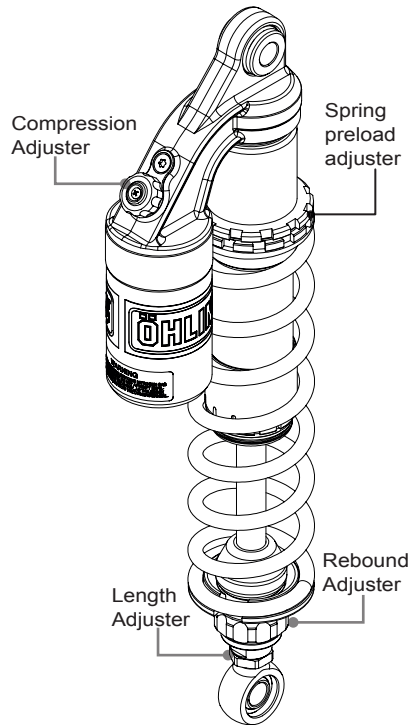

SETUP DATA

Recommended set-up

Spring Preload.....	17 mm.
Compression adjuster.....	2 Clicks
Rebound adjuster	18 Clicks

Shock absorber data

Length	378 ⁺⁸ / ₋₂ mm.
Stroke	94 mm.

Spring

Installed spring

Part No	60480-12
Free spring length...	230 mm
Spring rate.....	Prog 16-26 N/mm
Preload adj.range....	0-27 mm

👁 Öhlins products are subject to continuous improvement and development, therefore, although these instructions include the most up-to-date information available at the time of printing, minor updates may occur.

To find the latest information contact an Öhlins distributor. Please contact Öhlins if you have any questions regarding the contents in this document.

Part no. MI_DU 907_EN 0
Issued 2019-09-27

© Öhlins Asia Co. Ltd. All rights reserved. Any reprinting or unauthorized use without the written permission of Öhlins Racing AB is prohibited.

Öhlins Asia Co. Ltd
700/937 Moo5, Tambol Nongkhaga,
Amphur Phantong, Chonburi Province
20160 Thailand



www.ohlins.com