

# Owners Manual

## Mounting instructions Öhlins shock absorber kit BM 124 for BMW R 1150 RT front

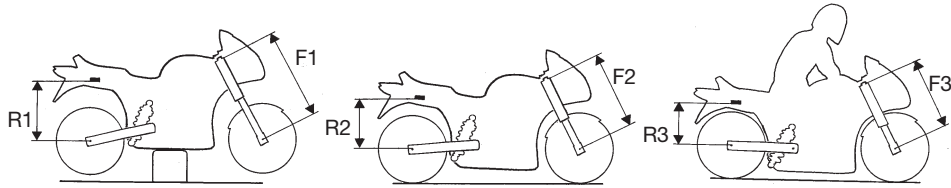

Bike on a stand.

Bike on the ground.

Bike with rider on.

### Setup data

Lenght	330 mm
Stroke	78 mm
Rebound adjustment	18 clicks
Preload	10 mm

### Checking sag and ride height

#### Front suspension

F1. Bike on a stand with the suspension fully extended = .....

F2. Bike on the ground without rider = .....

F3. Bike on the ground with rider = .....

**Free sag** F1 - F2 = .....

**Ride height** F1 - F3 = .....

#### Rear suspension

R1. Bike on a stand with the suspension fully extended = .....

R2. Bike on the ground without rider = .....

R3. Bike on the ground with rider = .....

**Free sag** R1 - R2 = .....

**Ride height** R1 - R3 = .....

#### NOTE!

*If ride height is higher than recommended, softer spring/springs must be used.  
If ride height is lower than recommended, harder spring/springs must be used.  
Contact your Öhlins dealer for advice.*



### Öhlins shock absorber 46 ER

#### Adjusters

Your Öhlins shock absorber type 46 ER features the following adjusters:

#### Rebound damping

Adjuster wheel on the piston shaft above the end bracket.

#### Spring preload

Adjustment made by rings on the cylinder house. Use C-spanner.

When delivered the Öhlins shock absorber is dialed to recommended settings for the specific brand and make of the motorcycle. If you have changed the setting check like this:

The adjusters have a normal right hand tread. Turn clockwise to fully closed. Turn counter clockwise to open and count the clicks until you reach the recommended number of clicks.

Do not use too much force, delicate sealing surfaces can be damaged. Use fingers only.

BM 124, issued 02 01 15



Öhlins Racing AB, Box 722, S-194 27 Upplands Väsby, Sweden.  
Phone +46 8 590 025 00. Fax +46 8 590 025 80.  
[www.ohlins.com](http://www.ohlins.com)

© Öhlins Racing AB. All rights reserved. Any reprinting or unauthorized use without the written permission of Öhlins Racing AB is prohibited. Printed in Sweden.



## Safety signals

Important information concerning safety is distinguished in this manual by the following notations:



**The Safety alert symbol means:  
Caution! Your safety is involved.**

### **WARNING!**

*Failure to follow warning instructions could result in **severe or fatal injury** to anyone working with, inspecting or using the suspension, or to bystanders.*

### **CAUTION!**

*Caution indicates that special precautions must be taken to avoid damage to the suspension.*

### **NOTE!**

*This indicates information that is of importance with regard to procedures.*

Öhlins products are subject to continual improvement and development. Consequently, although these instructions include the most up-to-date information available at the time of printing, there may be minor differences between your suspension and this manual. Please consult your Öhlins dealer if you have any questions with regard to the contents of the manual.

### **NOTE!**

*During storage and transportation, especially at high ambient temperature, the oil and grease used for assembling may run out inside the packing and damage the expanded polystyrene packing material. This is not unusual and is in no way detrimental to the shock absorber.*

## Kit contents

Before installing the shock absorber, please check the contents of the kit, listed on the front page of this instruction. If anything is missing, contact your Öhlins dealer.

Description	Pcs.	Part No.
Shock absorber 46ER	1	BM 124
Sticker Öhlins	2	00192-01
Sticker memo notes	1	01180-01
C-spanner	1	00710-02
Owners manual	1	

## Before installation

Öhlins Racing AB can not be held responsible for any damage whatsoever to shock absorber or vehicle, or injury to persons, if the instructions for fitting and maintenance are not followed exactly.

Similarly, the warranty will become null and void if the instructions are not adhered to.

### **WARNING!**

*1. Installing a shock absorber, that is not approved by the vehicle manufacturer, may affect the stability of your vehicle. Öhlins Racing AB cannot be held responsible for any personal injury or damage whatsoever that may occur after fitting the shock absorber. Contact an Öhlins dealer or other qualified person for advice.*

*2. Please study and make certain that you fully understand all the mounting instructions and the owners manuals before handling this shock absorber kit. If you have any questions regarding proper installation procedures, contact an Öhlins dealer or other qualified person.*

*3. The vehicle service manual must be referred to when installing the Öhlins shock absorber*

## Mounting instructions

**1**

Put the motorcycle on a stand so that the front wheel is clear of the ground. The front fork must be free, so that suspension is unloaded. Make sure it's steadily fixed so that it will not fall over.

### **WARNING!**

- 1. It's advisable to have an Öhlins dealer or other qualified person to fit your shock absorber.*
- 2. Instructions in the vehicle service manual are to be followed when changing the shock absorber.*
- 3. When working on a lifted vehicle it must be securely supported to prevent it from falling.*

**2**

Remove the rear view mirrors by pulling them outwards.

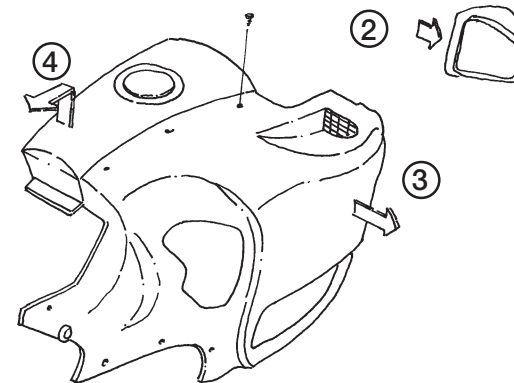

**3**

Loosen the front side fairings and lift them off the bike, so the fuel tank is accessible.

**4**

Loosen and pull the fuel tank backwards so the upper shock absorber mount can be reached.

**5**

Remove the original shock absorber by first loosening the lower bracket, then the upper mounting. The lower bracket is accessible from the front of the motorcycle.

**6**

Mount the Öhlins shock absorber in reverse order, first the upper attachment then the lower one. Use the original rubber mounts to the upper bracket.

**7**

Refit the fuel tank, side covers and seats.

### **NOTE!**

*Make sure that all bolts are tightened to the correct torque and that nothing fouls or restricts movement of the shock absorber when the suspension is being fully compressed or extended.*

**8**

Continue your work according to Owners manual.