



Note!

Please note that there can be small differences between your product and the images in these instructions.

Note!

Please note that during storage and transport, especially at high ambient temperature, some of the oil and grease used for assembly may leak and stain the packaging. This will not cause damage to the product, wipe off the excessive oil or grease with a cloth.

Note!

Before you install this product, check the kit contents. If anything is missing, please contact an Ohlins dealer.

Warning!

Before you install this product, read the Ohlins Owner's manual. This product is an important part of the vehicle and the vehicle stability.

Shock absorber for Porsche 911 Carrera 4/ Turbo (997)

POZ MN05

Mounting Instructions

KIT CONTENTS

Front	
Description	Pcs
Adapter ring	2
Anti roll bar bracket, left	1
Anti roll bar bracket, right	1
Dust boot	2
Elastic spacer	2
Heat shrinkable end cap	2
Lock nut M14	2
Lock ring	4
Plastic Spacer	2
Screw M6	2
Shock absorber	2
Sleeve	2
Spring	2
Spring platform	2

Rear	
Description	Pcs
Adapter ring	2
Adjuster	(2)*
Adjustment cup	(2)*
Bump rubber	(2)*
Dust boot	2
Elastic spacer	2
Heat shrinkable end cap	2
Lock nut M12	2
Lock ring	4
Nut M12x1.25	2
Plastic Spacer	2
Rubber spacer	(2)*
Screw M12x1.25	2
Shock absorber	2
Spacer	(2)*
Spring	2
Spring platform	2
Washer	2

Used for both front and rear	
Description	Pcs
C-spanner single	2
Owners's manual	1
Sticker set R&T	1

* Parts mounted on the shock absorber at delivery.

MOUNTING INSTRUCTIONS

⚠ Warning!

We strongly recommend to let an Öhlins dealer install this product.

⚠ Warning!

If you work with a lifted vehicle, make sure that it is safely supported to prevent it from tipping over.

👁 Note!

When you work with this product, see the vehicle service manual for vehicle specific procedures and important data.

👁 Note!

Before you install this product clean the vehicle.

MOUNTING INSTRUCTIONS

1

Front and rear:

Remove the original shock absorbers from the vehicle, see the vehicle service manual for correct procedure.

2

Front:

Remove the:

- top washer
- top mount
- bearing
- rubber insulator
- lower washer

from the original strut. Note that you will need these parts to install the Öhlins strut.

Rear:

Remove the top mount from the original shock absorber. Note that you will need this part to install the Öhlins shock absorber.

⚠ Warning!

The spring is preloaded so take precaution when you remove the spring from the shock absorber.

3 Front and rear

Cut the dust boot:

Front: 62 mm from the lower end.

Rear: 82 mm from the lower end.

4 Front and rear

Assemble the strut/shock absorber, see figures 4A (front) and 4B (rear).

👁 Note!

Rear: *Remove the golden colored cup before you install the spring seat and the lock nuts on the shock absorber.*

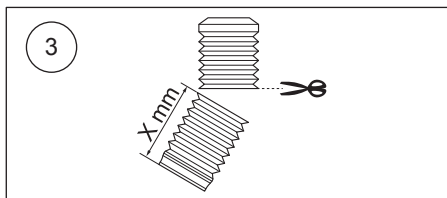

MOUNTING INSTRUCTIONS

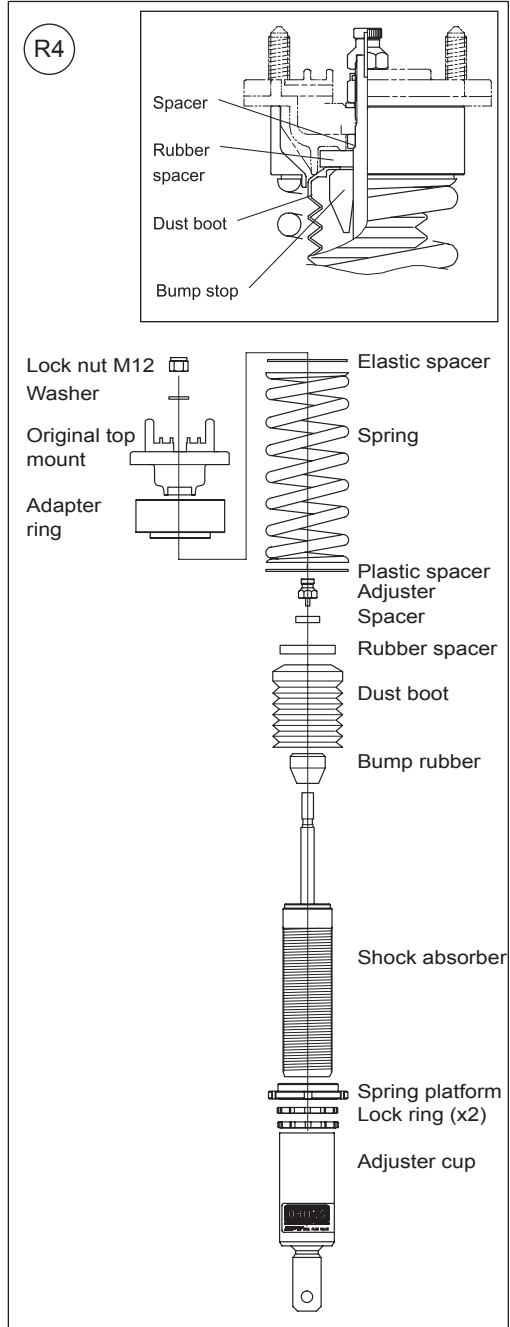
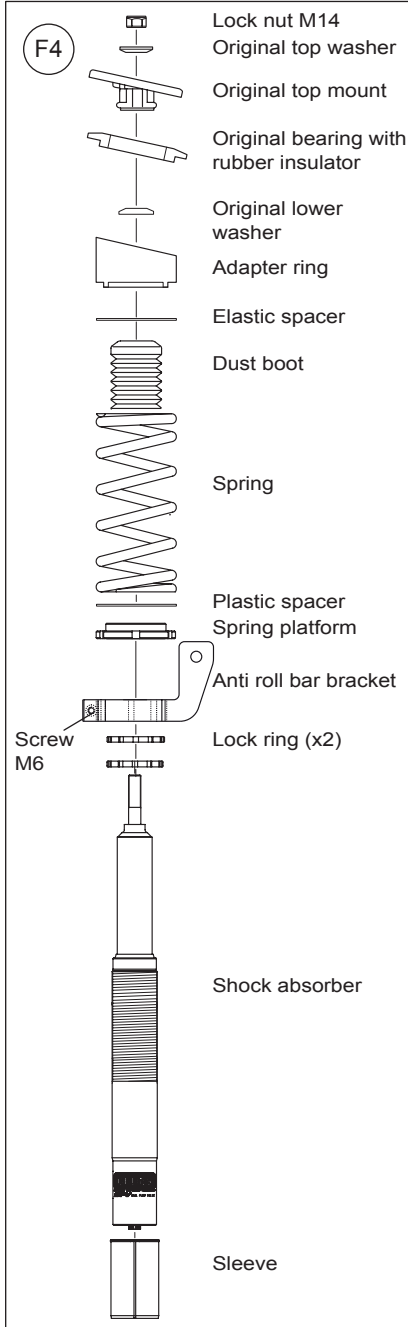

MOUNTING INSTRUCTIONS

5

Front and rear:

Set the installation dimensions according to fig F5 and R5. You may need to change these to reach the target height.

👁 **Note!**

After you have installed all shock absorbers/struts you must check and adjust height. See section *Adjustments and Setup data*.

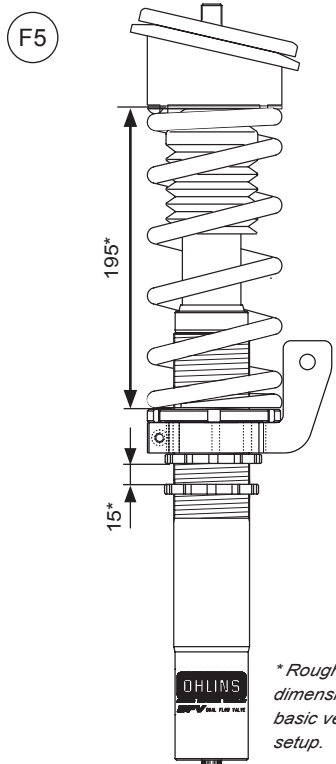

F5

195*

15*

* Rough dimensions for basic vehicle setup.

Tighten:

Lower spring seat and lock ring: 50-60 Nm
Lock nut M14: 35-40 Nm
Anti roll bar bracket screw M6: 12-15 Nm

👁 **Note!**

When you tighten the top mount nut, hold the strut top pin in position with a 6 mm Allen key

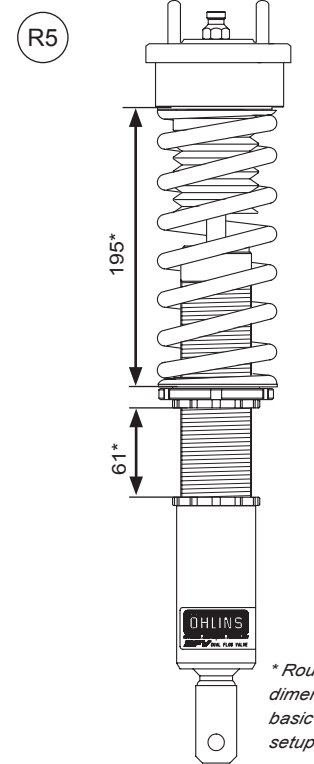

R5

195*

61*

* Rough dimensions for basic vehicle setup.

Tighten:

Lower spring seat and lock ring: 50-60 Nm
Lock nut M12: 30-35Nm

👁 **Note!**

When you tighten the top mount nut, hold the shock absorber shaft in position with a flat screwdriver.

MOUNTING INSTRUCTIONS

6

Front:

Install the Öhlins strut on the vehicle according to the vehicle service manual.

Rear:

Install the Öhlins shock absorber on the vehicle according to the vehicle service manual.

Use the supplied screw and nut for the lower attachment. Tighten according to the vehicle service manual.

⚠ Caution!

Ensure that all screws are tightened to the correct torque and that nothing fouls or restricts movement of the strut/shock absorber when the suspension is fully compressed or extended.

👁 Note!

Make sure that all removed parts, except the replaced parts, are reinstalled in the same positions as they were before the installation of the Öhlins shock absorbers.

7

Front and rear:

If the vehicle is equipped with PASM, disable the PASM function in the ECU to avoid getting error codes. Carefully shrink the heat shrinkable end cap over the PASM connector to protect it. See the vehicle manual.

8

Front:

Position the anti roll bar bracket, see figure.

👁 Note!

Parts for step 9 need to be ordered separately.

9

Rear:

If the car is equipped with the BOSE loud speaker system you will need a wire adjuster.

Part numbers:

24631-01 (1 pc/side)

24632-02 (1 pc/side)

24633-01 (1 pc/side)

24633-02 (1 pc/side)

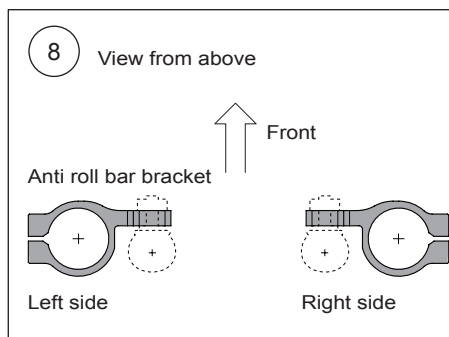

ADJUSTMENTS

⚠ Warning!

Before you drive, always make sure that the setup is according to the recommended setup data. Read about adjustments and setting up in the Öhlins Owner's Manual before you make any adjustments. Contact an Öhlins dealer if you have any questions about setting up.

👁 Note!

All dimensions are applicable for vehicles with original wheel dimensions.

Set vehicle height

When the Öhlins dampers are setup according to figures F5 and R5 and installed on the vehicle we recommend to set the height.

Definitions:

- A; Highest point on fender to ground.
- B; Highest point on fender to center of wheel.
- B'; Highest point of fender to lower edge of rim.
- D; Diameter of rim (measured)

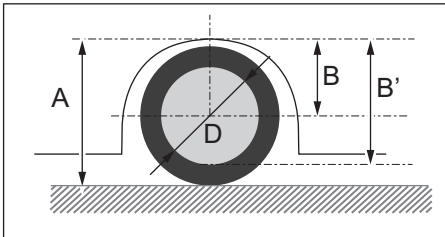

Actual vehicle height:

The target height (B) for your vehicle with the Öhlins dampers installed is:

- front: 345 mm
- rear: 350 mm

To calculate target height (B):

1. Measure the rim (D).
2. Measure from the lowest point of the fender to the lowest edge of the rim and subtract half the diameter of the rim (D).

$$B = B' - D/2$$

If the height needs to be adjusted to reach the target height, change the length of the damper with the lower lock ring on the front damper and by moving the golden cup on the rear damper.

👁 Note!

Do not adjust outside the recommended range. Tighten to the specified torque after you have adjusted.

SETUP DATA

Adjuster settings		
Track use	0-7	clicks
Winding road	5-10	clicks
Street	10-20	clicks
Spring		
Free length	197-203	mm
Spring rate	Front 70 N/ mm	
	Rear 120 N/mm	
Preload	5	mm

To calculate installed spring length:

Free length of the spring - Spring preload (see table) = Installed spring length

Vehicle height

The height of the vehicle is set with the dampers on the car according to the instructions in the Owners Manual.

The length of the front strut can be adjusted in the range between +15 mm (to raise) and -12 mm (to lower) from the reference length. +15 mm should be close to the original height of the front of the vehicle and -12 a lowering of approx 35-40 mm compared to the original car.

The length of the rear shock absorber can be adjusted in the range between +15 mm (raise) and -10 mm (lowering) from the reference length.

+15 mm should be close to the original height of rear of the vehicle and -10 a lowering of approx 35-40 mm compared to the original car.

Öhlins products are subject to continuous improvement and development, therefore, although these instructions include the most up-to-date information available at the time of printing, minor updates may occur.

To find the latest information contact an Öhlins distributor. Please contact Öhlins if you have any questions regarding the contents in this document.

Part no. MI_POZMN05_1
Issued 2015-04-30

© Öhlins Racing AB. All rights reserved. Any reprinting or unauthorized use without the written permission of Öhlins Racing AB is prohibited.

Öhlins Racing AB
Box 722
S-194 27 Upplands Väsby, Sweden
Phone +46 8 590 025 00
fax +46 8 590 025 80



www.ohlins.com