



👁 Note!

Please note that this image is a general representation of the product and may differ slightly from your product.

👁 Note!

Please note that during storage and transportation, especially at high ambient temperature, some of the oil and grease used for assembling may leak and stain the packaging. This is in no way detrimental to the product, wipe off the excessive oil/grease with a cloth.

Kit Contents		
Description	Part No	Pcs
Shock absorber		2
Upper spring seat	24637-02	2
Lower spring seat	24635-02	2
Dust boot	10216-01	2
Lock nut	24636-02	2
Spring		2
Washer		2
Nut M14	24627-04	2
Rebound adjuster	24631-02	2
Used for front and rear		
C-spanner		2
Öhlins sticker		1
Öhlins Owner's Manual		1

👁 Note!

Before installing this product, check the contents of the kit. If anything is missing, please contact an Öhlins dealer.

⚠ Warning!

Before installing this product, read the Öhlins Owner's Manual. The shock absorber is an important part of the vehicle and the vehicle stability.

Shock absorber Kit for BMW 3 series (E90) - front

BMS M100

Mounting Instructions



MOUNTING INSTRUCTIONS

⚠ Warning!

We strongly recommend to have an Öhlins dealer install this product.

⚠ Warning!

If working on a raised vehicle, ensure that it is securely supported to prevent it from tipping over.

👁 Note!

When working on this product, see the Vehicle Service Manual for vehicle specific procedures and important data.

1

Raise the vehicle and put it on jack stands.

⚠ Warning!

Ensure that it is securely supported.

2

Remove the front wheels.

3

Remove the stabilizer links and brake hose brackets from the standard struts.

4

Loosen the bolts for the lower strut attachments.

👋 Caution!

Support the wheel hubs in an appropriate way on each side of the vehicle so that the brake hoses can not be damaged.

5

Loosen the upper attachments. Remove the original struts from the car.

6

Tighten the lower spring seat and the lock nut to 50 - 60 Nm.

Fit the dust boot, the spring and the upper spring seat to the strut according to fig 1

Fit the standard lower bearing spacer, the standard top mount and the standard top nut. Tighten the top nut to 35 - 40 Nm.

7

Install the Öhlins McPherson struts on the vehicle according to fig 2.

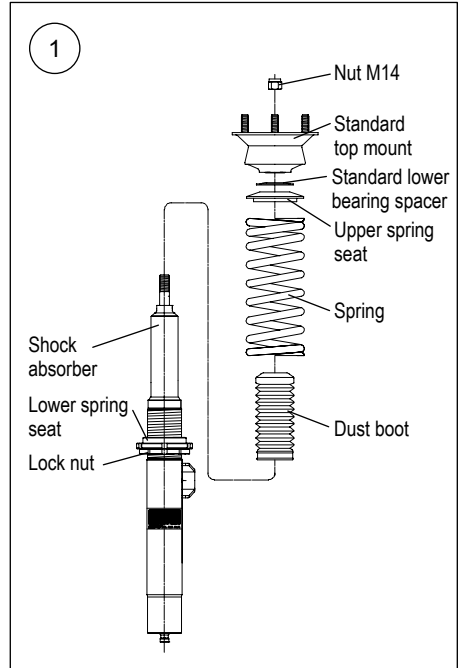

2

👋 Caution!

Match the projection for positioning the shock absorber to the opening of the hub and assemble it.

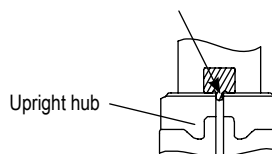

MOUNTING INSTRUCTIONS

8

Mount the standard stabilizer links and standard brake hose brackets to the Öhlins struts according to fig 3. Tighten the nut to 6 Nm.

Note!

When tightening the top mount nut, the shock absorber shaft must be held in position with a 5 mm Allen key.

9

Fasten the upper attachments.

10

Raise the wheel hub with a jack to remove the freeplay of the lower strut attachment bolts before tightening them.

Note!

Make sure that all bolts are tightened to the correct torque and that nothing fouls or restricts movement of the strut when it is being fully compressed or extended. Test this over the whole steering range from lock to lock.

11

Make sure that all removed parts are reinstalled in the same way as they were before the installation of the Öhlins shock absorber.

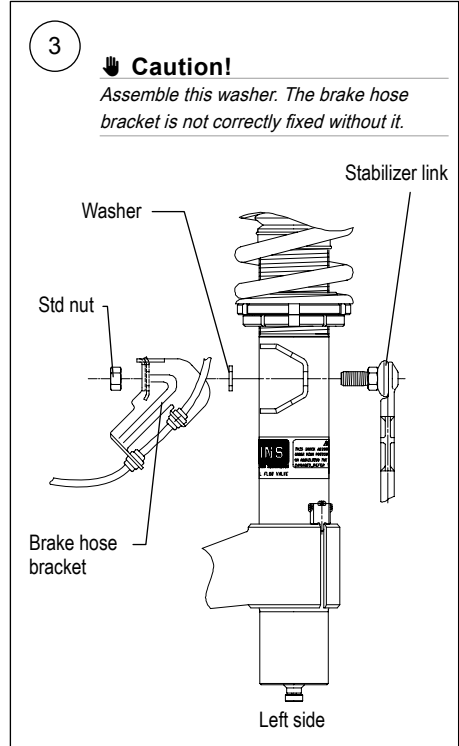

ADJUSTMENTS

⚠ Warning!

Before riding, always make sure that the basic settings made by Öhlins are according to recommended Set-up Data. Read about adjustments and setting up in the Öhlins Owner's Manual before you make any adjustments. Contact an Öhlins dealer if you have any questions about setting up.

The standard preload is 7 mm from a free length of 200 mm, giving 193 mm installed length, see fig 6.

SETUP DATA

Recommended set-up

Rebound	10	clicks
Spring preload	7	mm
Shock absorber length	401	mm
Spring		
Spec H200/ ID65	60	N/mm

The actual vehicle height

With both the preload and height adjustments in their standard positions, the vehicle is lowered approximately 20 mm when compared to the original suspension. As the height adjuster is turned one rotation, the position moves 2.0 mm.

⚠ Warning!

The adjustment range is the standard position -3 to +15 mm.

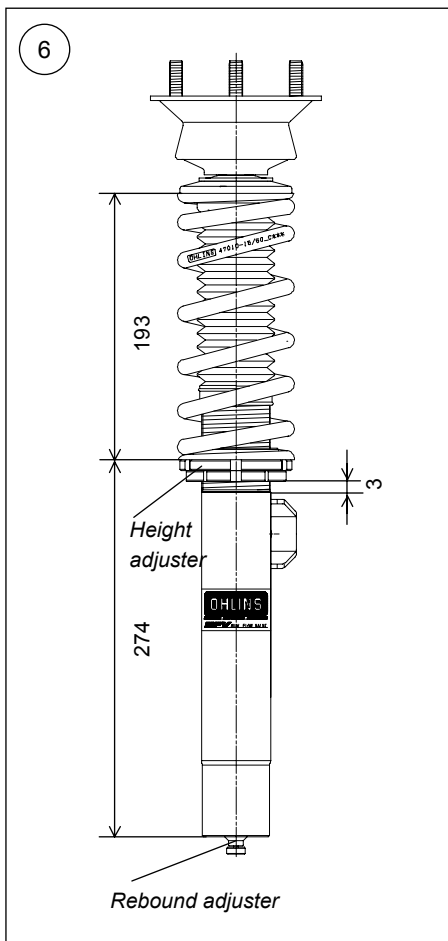

Öhlins products are subject to continuous improvement and development, therefore, although these instructions include the most up-to-date information available at the time of printing, minor updates may occur.

To find the latest information contact an Öhlins distributor. Please contact Öhlins if you have any questions regarding the contents in this document.

Part no. MI_BMSMI00_front_4
Issued 2017-03-02

© Öhlins Racing AB. All rights reserved. Any reprinting or unauthorized use without the written permission of Öhlins Racing AB is prohibited.

Öhlins Racing AB
Box 722
S-194 27 Upplands Väsby, Sweden
Phone +46 8 590 025 00
fax +46 8 590 025 80



www.ohlins.com



Kit Contents		
Description	Part No	Pcs
Shock absorber		2
Lock nut M10	24627-01	2
Dust boot	10216-01	2
Control wire	24631-03	2
Adjustment knob	24633-01	2
Screw M4	24633-02	2
Allen key		1
Spring		2
Spring hight adjuster	24651-02	2
Lock ring	24636-03	2
Spring seat	24635-03	2
Rubber seat (t=2mm)	25601-03	2
Rubber seat (t=5mm)		2
Plastic seat	25618-04	2
Mounted on schock absorber		
Adjuster	24631-03	2

👁 Note!

Please note that this image is a general representation of the product and may differ slightly from your product.

👁 Note!

Please note that during storage and transportation, especially at high ambient temperature, some of the oil and grease used for assembling may leak and stain the packaging. This is in no way detrimental to the product, wipe off the excessive oil/grease with a cloth.

👁 Note!

Before installing this product, check the contents of the kit. If anything is missing, please contact an Öhlins dealer.

⚠ Warning!

Before installing this product, read the Öhlins Owner's Manual. The shock absorber/front fork/steering damper is an important part of the vehicle and the vehicle stability.

Shock absorber Kit for BMW 3 series (E90) - rear

BMS M100

Mounting Instructions

MOUNTING INSTRUCTIONS

⚠ Warning!

We strongly recommend to have an Öhlins dealer install this product.

⚠ Warning!

If working on a raised vehicle, ensure that it is securely supported to prevent it from tipping over.

👁 Note!

When working on this product, see the Vehicle Service Manual for vehicle specific procedures and important data.

1

Raise the vehicle and put it on jack stands.

⚠ Warning!

Ensure that it is securely supported.

2

Remove the rear wheels.

3

Remove the lower and the upper attachments and remove the original shock absorbers.

4

Remove the spring.

5

Set the spring seat of the spring height adjuster to the position according to fig 4 and 6.

6

Remove the OEM upper spring cup according to figure 2.

7

Install the Öhlins spring, the spring height adjuster, the rubber seats and the plastic seat on the vehicle according to fig 4.

8

Fit the dust boot, the std rubber bushes, the std washer and adjuster according to fig 1
Tighten the lock nut to 20 Nm.
The std nut must be removed from the std bush according to fig 3.

👁 Note!

When tightening the lower mount nut, the shock absorber shaft must be held in position with a 5 mm spanner.

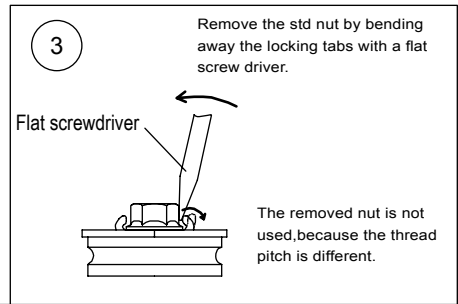
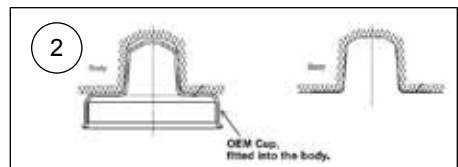
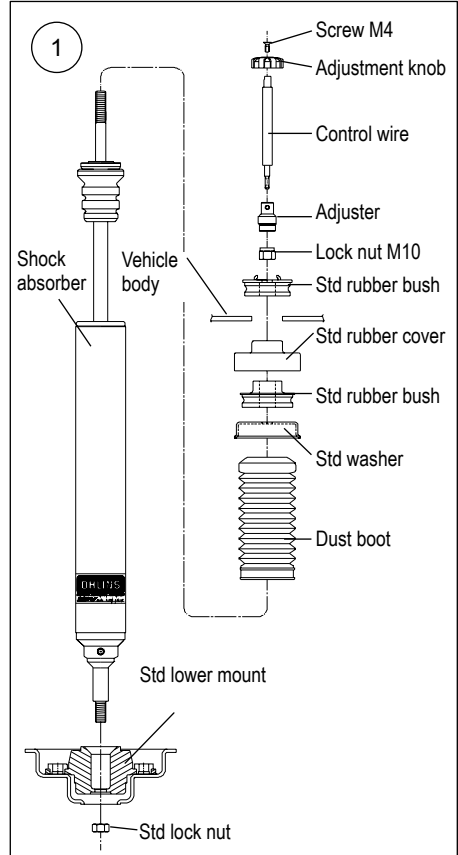

MOUNTING INSTRUCTIONS

9

Install the Öhlins shock absorbers on the vehicle.

10

Fasten the upper attachments.

👁 **Note!**

Make sure that all bolts are tightened to the correct torque and that nothing fouls or restricts movement of the shock absorber when it is being fully compressed or extended.

11

Make sure that all removed parts are reinstalled in the same way as they were before the installation of the Öhlins shock absorber.

12

Sub-assemble the wire.

(Fasten the adjustment knob by tightening the M4 screw.)

As shown in fig 5, insert the wire through the $\varnothing 10$ hole which is made in the side panel, and run it inside the panel.

Insert the top end of the wire into the adjuster and fasten it with the supplied Allen key.

4

Set the spring height adjuster, the spring seat, the lock ring, the rubber seats and the plastic seat to the fitting in the figure below.

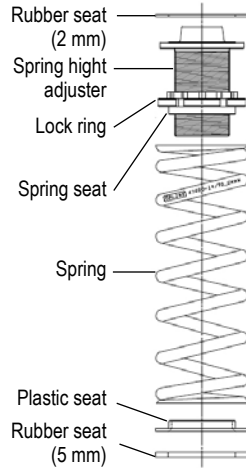

5

Make a $\varnothing 10$ hole in the side panel in the shown position and pass the control wire through it.

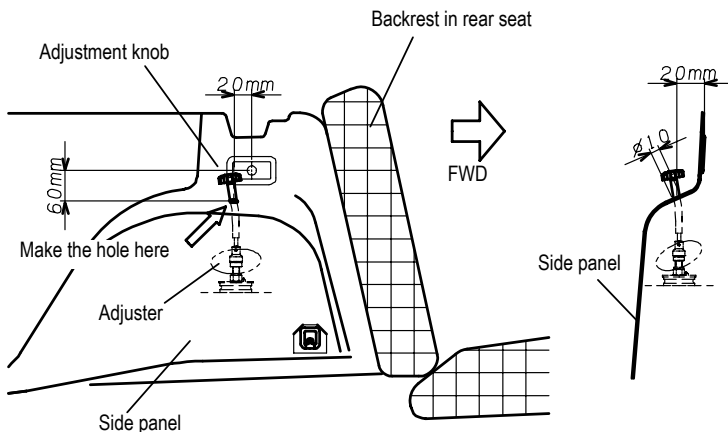

Left side of vehicle body inside trunk room

ADJUSTMENTS

⚠ Warning!

Before riding, always make sure that the basic settings made by Öhlins are according to recommended Set-up Data. Read about adjustments and setting up in the Öhlins Owner's Manual before you make any adjustments. Contact an Öhlins dealer if you have any questions about setting up.

SETUP DATA

Recommended set-up

Rebound 10 clicks

Spring height adjuster 62 mm
(see fig 5)

Spring

Spec H250/ ID65 70 N/mm

The actual vehicle height

With the height adjustments in their standard positions, the vehicle is lowered approximately 25 mm when compared to the original suspension. As the height adjuster is turned one rotation, the position moves 1.5 mm.

⚠ Warning!

The adjustment range is the standard position ± 15 mm. If the spring height adjuster is moved outside the adjustment range, the spring might drop out.

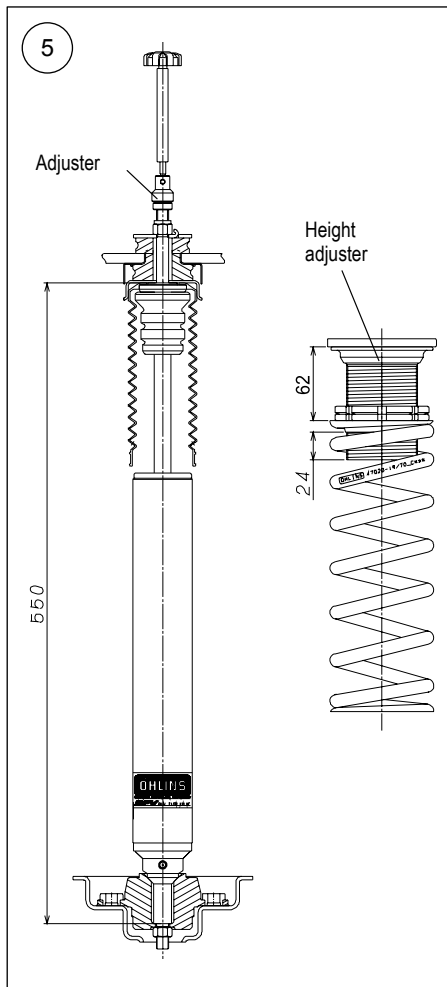

Öhlins products are subject to continuous improvement and development, therefore, although these instructions include the most up-to-date information available at the time of printing, minor updates may occur.

To find the latest information contact an Öhlins distributor. Please contact Öhlins if you have any questions regarding the contents in this document.

Part no. MI_BMSMI00_rear_4
Issued 2017-03-02

© Öhlins Racing AB. All rights reserved. Any reprinting or unauthorized use without the written permission of Öhlins Racing AB is prohibited.

Öhlins Racing AB
Box 722
S-194 27 Upplands Väsby, Sweden
Phone +46 8 590 025 00
fax +46 8 590 025 80



www.ohlins.com